

PACKARD
Industries, Inc.

STORAGE & FILING

**PEDESTALS, BOOKCASES, LATERALS,
WARDROBES, STORAGE CABINETS**

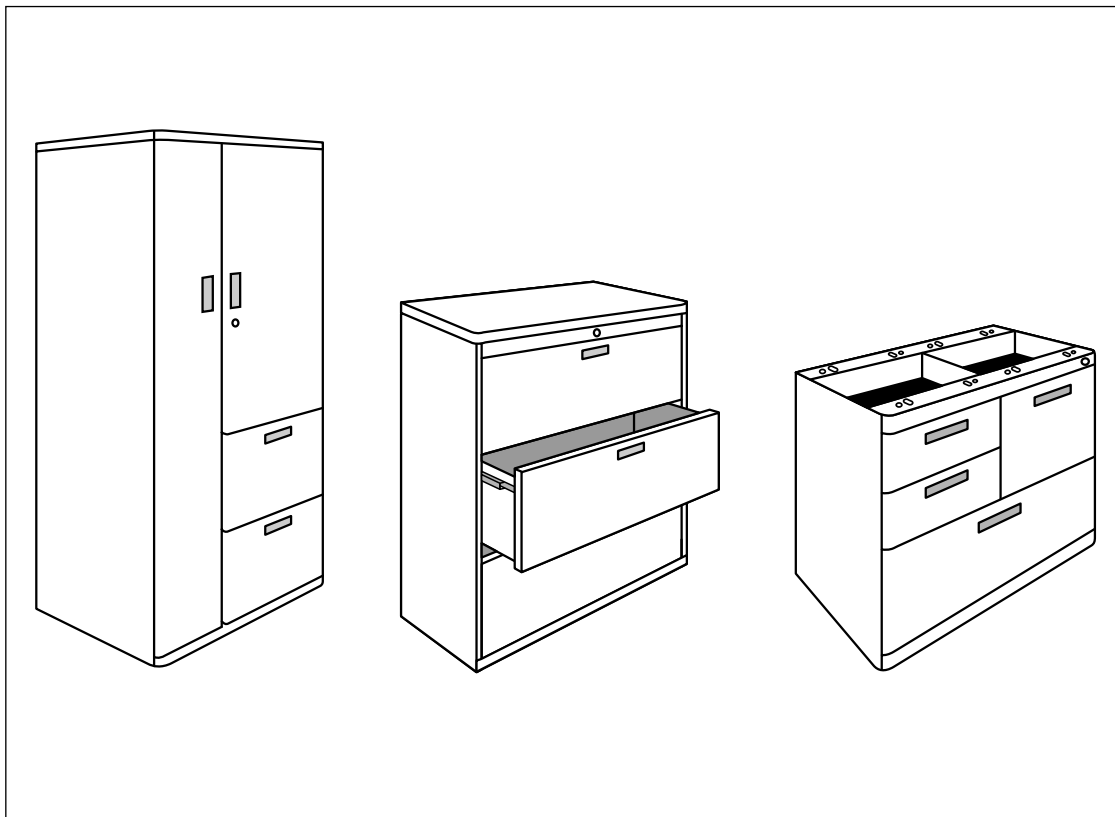

- VQS ➡ Indicates product available on the NAVA and NAVA FS Quickship Program
- See p. 2 for Ordering, Freight and VQS ➡ Quickship Program Terms
 - See p. 4 for Finish Selections

EFFECTIVE APRIL 2, 2008
PLEASE USE THESE 2001 COMBINED LIST PRICES PLUS 17%!

CALL: (800) 253-0866

75

FAX ORDERS TO: (269) 684-2422

**STORAGE
& FILING**

STORAGE & FILING

ZONE 1 LIST PRICES

Pedestals Price Each

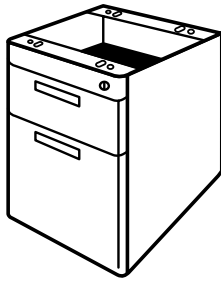

PED-1's: Worksurface Suspended

Drawer Style	Nominal Size	Part No.	Price Each	Weight
Box, File	15" w x 18" d x 19" h (use with all Axis units)	PED-1-18	\$332.	45#
Box, File	15" w x 22" d x 19" h	PED-1	\$332.	45#

- Open-Top Worksurface suspended with "Quickmount" attachment.

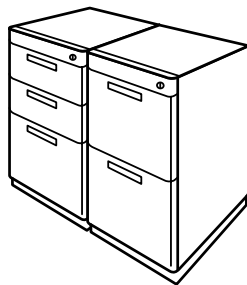

PED-2's: Freestanding

Drawer Style	Nominal Size	Part No.	Price Each	Weight
Box, Box, File	15" w x 22" d x 28" h	PED-2	\$480.	75#
File, File	15" w x 22" d x 28" h	PED-2/2	\$480.	75#

- Closed-Top freestanding.



PED-3's: Mobile

Drawer Style	Nominal Size	Part No.	Price Each	Weight
Box, Box, File	15" w x 22" d x 28" h	PED-3	\$492.	70#
File, File	15" w x 22" d x 28" h	PED-3/2	\$492.	70#

- Closed-Top mobile.

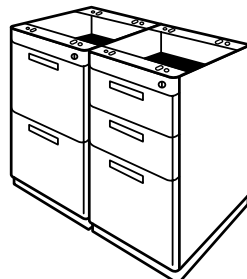

PED-5's: Worksurface Supporting

VQS ⇒

VQS ⇒

Drawer Style	Nominal Size	Part No.	Price Each	Weight
Box, Box, File	15" w x 22" d x 28" h	PED-5	\$412.	59#
File, File	15" w x 22" d x 28" h	PED-5/2	\$412.	59#

- Open-Top Worksurface supporting.

Add for Keyed Alike	KEYD	\$16.
---------------------	------	-------

VQS ⇒ Available on Quickship.

- Price each includes one divider per drawer, and lock with removable core.
- Other depths and drawer configurations available. Please consult the factory.
- Optional color-matched drawer pulls available. Please see p. 80.

STORAGE & FILING

ZONE 1 LIST PRICES

Pedestals Price Each

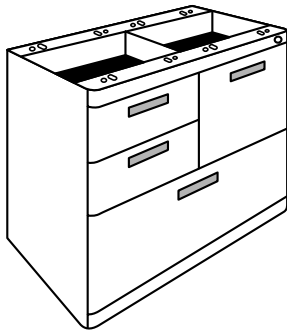

PED-10's: Worksurface Supporting

Drawer Style	Nominal Size	Part No.	Price Each	Weight
Box, Box, File Lateral	30"w x 18"d x 28"h	PED-10	\$880.	114#

- Open-Top Worksurface supporting.

Add for Keyed Alike	KEYD	\$16.
---------------------	------	-------

- Price each includes one divider per drawer, file conversion kit, and lock with removable core.
- Other depths and drawer configurations available. Please consult the factory.
- Optional color-matched drawer pulls available. Please see p. 80.

Center Drawer Price Each

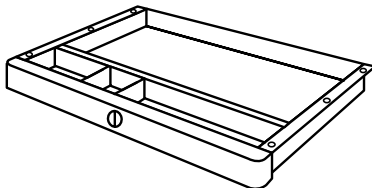

VQS ⇒

Nominal Size	Part No.	Price Each	Weight
20"w x 18"d x 2"h	CD-3	\$116.	11#

Add for Keyed Alike	KEYD	\$16.
---------------------	------	-------

VQS ⇒ Available on Quickship.

- Price each includes lock with removable core.

Personal Item Sub-Shelf Price Each

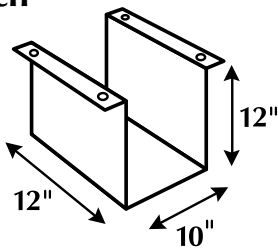

Nominal Size	Part No.	Price Each	Weight
10"w x 12"d x 12"h	SP-1	\$70.	5#

- Attaches under any worksurface.

Metal Bookcases Price Each

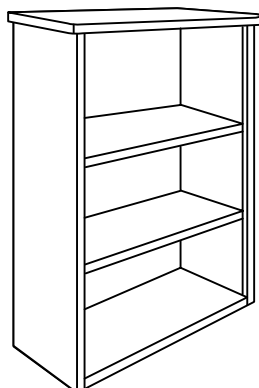

Shelf Style	Nominal Size	Part No.	Price Each	Weight
Two High One Adj. Shelf	34"w x 14"d x 29"h	MBK-236	\$424.	53#
Three High One Adj. Shelf	34"w x 14"d x 41"h	MBK-336	\$444.	60#
Four High Three Adj. Shelves	34"w x 14"d x 53"h	MBK-436	\$490.	83#

Additional Shelves and Clips	MBKS	\$48.	7#
------------------------------	------	-------	----

STORAGE & FILING

ZONE 1 LIST PRICES

Lateral Files Price Each

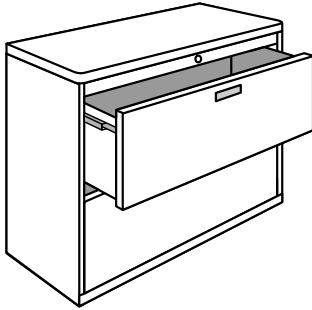

Lat-2's: Two Drawer

Nominal Size	Part No.	Price Each	Weight
30" w x 18" d x 28" h	LAT-230	\$682.	75#
36" w x 18" d x 28" h	LAT-236	\$734.	106#
42" w x 18" d x 28" h	LAT-242	\$800.	136#

• Two drawer.

Add for Optional Counterweight	WGT-2	\$146.	45#
--------------------------------	-------	--------	-----

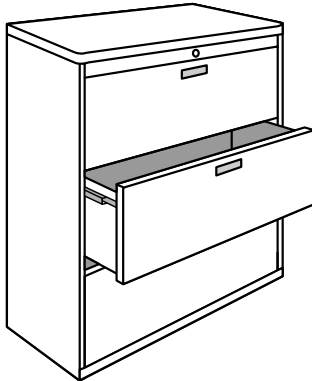

Lat-3's: Three Drawer

Nominal Size	Part No.	Price Each	Weight
30" w x 18" d x 40" h	LAT-330	\$852.	112#
36" w x 18" d x 40" h	LAT-336	\$954.	143#
42" w x 18" d x 40" h	LAT-342	\$1054.	174#

• Three drawer.

Add for Optional Counterweight	WGT-3	\$124.	33#
--------------------------------	-------	--------	-----

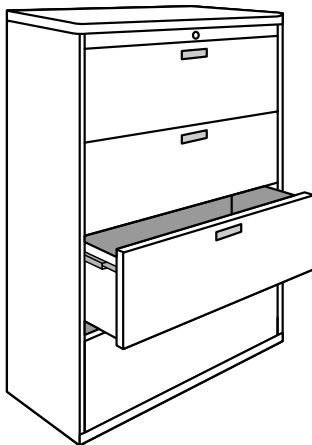

Lat-4's: Four Drawer

Nominal Size	Part No.	Price Each	Weight
30" w x 18" d x 52" h	LAT-430	\$1066.	161#
36" w x 18" d x 52" h	LAT-436	\$1184.	180#
42" w x 18" d x 52" h	LAT-442	\$1296.	211#

• Four drawer.

Add for Optional Counterweight	WGT-4	\$64.	23#
Add for Keyed Alike	KEYD	\$16.	

- Price each includes one file conversion kit per drawer, and lock with removable core.
- Optional color-matched drawer pulls available. Please see p. 80.
- Receding door lateral files available. Please consult the factory.

STORAGE & FILING

ZONE 1 LIST PRICES

Lateral Files

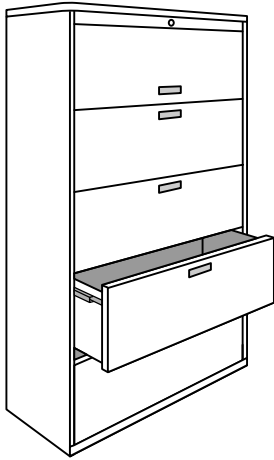

Lat-5's: Four Drawer, One Flip-up Door

Nominal Size	Part No.	Price Each	Weight
30" w x 18" d x 64" h	LAT-530	\$1344.	188#
36" w x 18" d x 64" h	LAT-536	\$1492.	219#
42" w x 18" d x 64" h	LAT-542	\$1658.	250#

- Four drawer, one Flip-up Door.

Add for Keyed Alike	KEYD	\$16.
---------------------	------	-------

- Price each includes one file conversion kit per drawer, and lock with removable core.
- Optional color-matched drawer pulls available. Please see p. 80.
- Receding door lateral files available at no upcharge. Please consult the factory.

Wardrobe Towers

Price Each

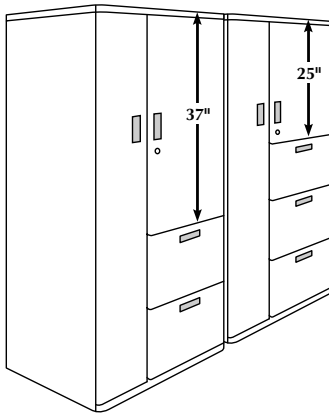

Drawer and Shelf Style	Nominal Size	Part No.	Price Each	Weight
File, File 37" Cupboard with Two Adj. Shelves	24" w x 24" d x 64" h	WBT-2/2	\$1864.	201#
File, File, File 25" Cupboard with One Adj. Shelf	24" w x 24" d x 64" h	WBT-2/3	\$1906.	205#

Add for Keyed Alike	KEYD	\$16.
---------------------	------	-------

- Price each includes one divider per drawer, hanging rod, and lock with removable core.
- Optional color-matched drawer pulls available. Please see p. 80.

Double Door Storage Cabinets

Price Each

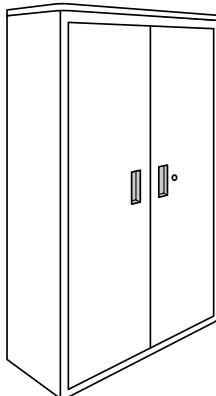

Shelf Style	Nominal Size	Part No.	Price Each	Weight
Two High One Adj. Shelf	36" w x 18" d x 28" h	DDS-236	\$702.	106#
Three High One Adj. Shelf	36" w x 18" d x 40" h	DDS-336	\$766.	143#
Four High Two Adj. Shelves	36" w x 18" d x 52" h	DDS-436	\$870.	180#
Five High Three Adj. Shelves	36" w x 18" d x 64" h	DDS-536	\$976.	250#

Additional Shelves and Clips	DDSS	\$48.	10#
Add for Keyed Alike	KEYD	\$16.	

- Price each includes lock with removable core.
- Optional color-matched drawer pulls available. Please see p. 80.

CALL: (800) 253-0866

79

FAX ORDERS TO: (269) 684-2422

STORAGE & FILING

ZONE 1 LIST PRICES

Accessories

- Additional items which may be added to a basic requirement. Order in addition to basic items.

1)

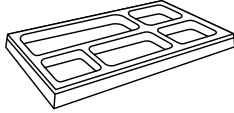

	Part No.	Price Each
1) Pencil Trays	PT-1	\$14./Ea.

Replacement Parts

- Items already included in pricing. Order as replacement items.

1)

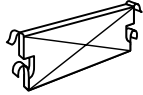

2)

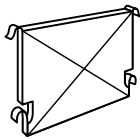

3)



	Part No.	Price Each
1) Additional 6" (Box) Drawer Dividers	BDD	\$14./Ea.
2) Additional 12" (File) Drawer Dividers	FDD	\$14./Ea.
3) Front-to-Back File Conversion Bar (pair)	FCB	\$14./Pr.

Special Pricing Upcharges

Upcharge for Color-Matched Drawer Pulls	CMDP	\$8./Ea.
---	------	----------

WORKING WITH STORAGE & FILING

ORDERING STORAGE AND FILING:

- All units are priced each. Price each includes one drawer divider in all 6" box and 12" file drawers, and one front-to-back file conversion kit in all lateral file drawers.
- Pedestal cabinets, 2-drawer lateral files, and 2-high storage cabinets are dimensioned to fit under work-surfaces, and may be used to support work-surfaces.
- Order optional counterweights for all lateral file units separately.
- For most units, nominal widths = actual widths; be sure to size your work-surfaces to allow the correct amount of space when placing units inside work-stations and wrapping the end with a panel (illustration #1).

Illustration #1:

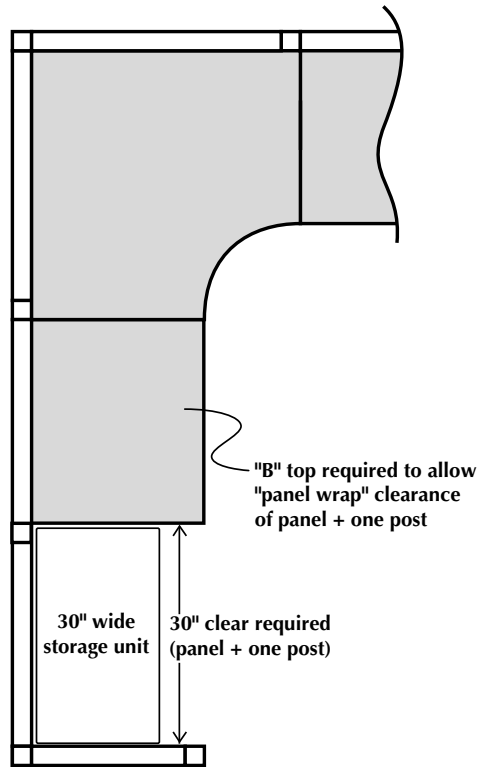

STORAGE & FILING SPECIFICATIONS

In General: All storage and filing units shall be of furniture grade steel construction, resistance welded to create sturdy and durable enclosures and drawers. All units shall have an integral base with levelling glides accessible from both the interior and exterior of the cases, allowing 5/8" to 1-5/8" height adjustment. All drawers are gang-locked with a master-keyed, core removable lock. Drawer and door pulls on all units are black plastic, recessed square pull. Optional color-matched drawer pulls and other drawer pull styles are available.

Material: Best quality steel, paint, and hardware. External surfaces shall be uniform and free of defects. All painted surfaces are spray coated with specially formulated high temperature baked enamel.

Pedestals: Shall have the general construction described above, with a 3/8" radius on the front vertical edges of all drawers. All 12" file drawers shall have full-extension ball bearing glides. All 6" box drawers shall have 3/4 extension nylon roller glides as standard. Optional ball bearing glides are available for 6" drawers. Mobile units shall have 2-locking and 2-non-locking casters. A variety of 3" pencil, 6" box, 12" file, and lateral file drawer configurations shall be available in 18", 22", and 28" depths. Lateral file drawers on the PED-10 shall have full extension ball bearing glides.

Center Drawers: Shall have the general construction described above, with a 3/8" radius on the front vertical edges of all drawers. Center drawers shall have a one piece steel housing and 3/4 extension ball bearing glides with take-apart feature.

Bookcases: Shall have the general construction described above. Shelves shall be adjustable in 2" increments.

Lateral Files: Shall have the general construction described above, with a 3/8" radius on the front vertical edges of all enclosures. All lateral file drawers shall have full extension ball bearing glides. A safety interlock system shall be included to prevent more than one compartment being opened at a time. Optional receding-flipper

door lateral files shall be available, with fixed shelves and either 12" or 15" opening heights. Optional counterweight shall be available.

Wardrobe Towers: Shall have the general construction described above, with a 3/8" radius on the front vertical edges of all drawers. All 12" file drawers shall have full-extension ball bearing glides. Shelves shall be adjustable in 2" increments. Storage doors shall have nickel-plated, self-closing, concealed hinges which allow for 110° opening, and shall be fully and easily adjustable both vertically and horizontally.

Storage Cabinets: Shall have the general construction described above, with a 3/8" radius on the front vertical edges of all enclosures. Shelves shall be adjustable in 2" increments. Storage doors shall have nickel-plated, self-closing, concealed hinges which allow for 110° opening, and shall be fully and easily adjustable both vertically and horizontally.

Baked Enamel Finishes: Available in a variety of colors of your choice. Metal surfaces shall be cleaned, phosphatized and double sprayed. High solids baked enamel shall be used. Finish shall be electrostatically applied and shall undergo deep-bake cycle at a temperature of 350°F.

Packing: All storage and filing units shall be fully assembled and individually packaged for shipment in properly designed shipping containers and palletized whenever possible.

Workmanship: All storage and filing units shall be constructed using only the best quality materials and workmanship. There shall be no rough edges or defects.

Performance Tests: All storage and filing units shall meet or exceed all applicable ANSI/BIFMA standards. Tests available upon written request.

Dimensions: All listed dimensions are nominal. Consult ordering notes or factory for precise dimensions.

